

Operating Instructions

for aerosol extinguishing generators of the 200/300/2000 PA series



Dynamit Nobel Defence

Dear customer,

The purpose of these operating instructions is to ensure safe use of Dynameco-PA01 series aerosol fire extinguishing generators in pneumatic fire extinguishing systems. The Dynameco-PA01 product range (fig 1) covers the following extinguishing generator types:

- Dynameco 200-PA01
- Dynameco 300-PA01
- Dynameco 2000-PA01

Please note the following points after opening the packaging:



- Read through these operating instructions carefully and in full before installing the first aerosol extinguishing generator.
- After removal from the packaging check each aerosol extinguishing generator for external damage.

In each packaging unit there is an installation tag for each extinguishing generator for recording the installation date.

Content of operating instructions

1. How Dynameco fire extinguishing generators work
2. Areas of use and special features of extinguishing with pyrotechnically formed aerosols
3. Special features of pneumatic activation
4. Storage
5. Assembly and installation
6. Commissioning
7. Disassembly
8. Periodic monitoring
9. Disposal
10. Age restriction
11. Warnings to prevent misuse
12. Assembly drawing



Important:

The sections in these operating instructions marked with warning symbols relate to your safety and the operating safety of the aerosol extinguishing generator and should therefore be carefully observed

1. How Dynameco fire extinguishing generators work

The way in which this fire extinguishing system works is based on the generation of an aerosol composed of extremely finely dispersed particles of the extinguishing agent potassium carbonate (K_2CO_3), which is formed by combustion of a pyrotechnical substance.

This aerosol extinguishing agent is designed to extinguish the flames of a fire.

The extinguishing process is based on the binding of what are termed intermediate reaction products (free radicals) and combustion energy on the surface of the aerosol cloud released. The atmospheric oxygen remains intact in this process.

2. Areas of use and special features of extinguishing with pyrotechnically formed aerosols

Pyrotechnic aerosol extinguishing generators in the Dynameco product range can be used to extinguish individual objects or specific room volumes.

In the planning either of these, the following should be taken into account:

- a) For object-based extinguishing the outflow opening the aerosol extinguishing generator must be aimed directly at the fire-endangered area.
- b) In the case of room flooding take care to ensure that the extinguishing agent concentration is correct. The room volume protected by the type of extinguishing generator can be found in the specific data sheets.
- c) Activating the aerosol extinguishing generators can lead to considerably reduced visibility. The effects can if necessary be mitigated by the appropriate technical measures



Important:

Because the extinguishing agent interrupts the chemical reaction in the flames of the fire but has no cooling effect, the fire must be tackled in its initial phase. This prevents the occurrence of excessive heat and hot surfaces, which if the concentration of the extinguishing agent diminishes can lead to re-ignition. In this context, it should be ensured that in the event of a fire the concentration of the extinguishing agent is maintained for as long as possible

Operating Instructions

for aerosol extinguishing generators of the 200/300/2000 PA series

3. Special features of pneumatic activation



Important:

- The aerosol stream generated by the extinguishing process is hot. A minimum clearance of 1,5 m should be maintained for both people and objects.
- **Do not touch the extinguishing generator after use: Risk of burns!**



Important:

After combatting the fire, all objects and surfaces affected by the fire and extinguishing procedure should be cleaned of residues. For further information please read the cleaning instruction.

The basic design of the fire extinguishing system based on the Dyameco-PA01 series aerosol fire extinguishing generators is composed of the following components:

- One or more Dyameco-PA01 extinguishing generators (fig 2 a)
- A sensor hose system of a length and layout appropriate to the application (fig 2 b)
- A pressure accumulator unit for adjusting and maintaining the system pressure (fig 2 c)

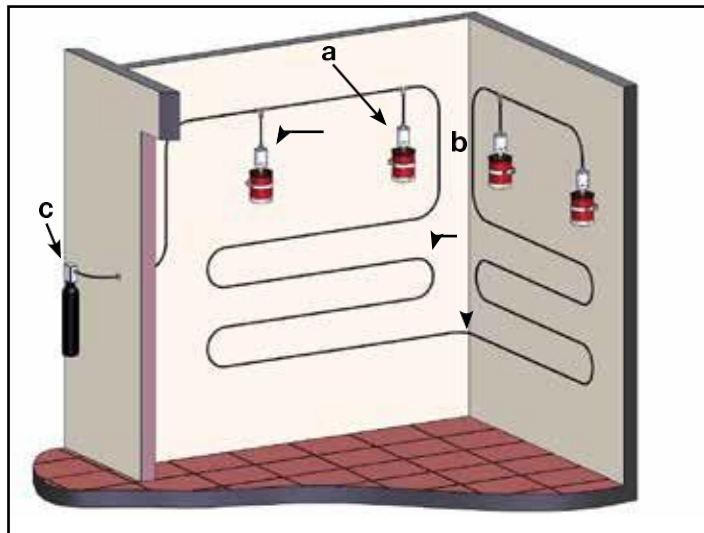

Fig 2: Basic system layout

This system combines the benefits of independence from an external power supply with the possibility of serial activation of several aerosol extinguishing generators as well as flexible integration of individual system components. The aerosol extinguishing generators are pneumatically triggered by the activation of the tripping head on the cover. The release pulse is generated in the event of a fire by a sudden pressure drop in the pneumatic fire detection system, caused by a burst in the sensor hose which occurs at a specified temperature.

The basic design of the pneumatic fire detection system described here can be supplemented by other system components. For further information please see our website:

www.dynameco.com



Important:

- The information required for the correct design and layout of a complete extinguishing system with integrated Dyameco-PA01 extinguishing generators and the limitations of the system do not form part of these operating instructions. To plan and install such a system it is necessary to refer to the operating and installation instructions for pneumatic Dyameco fire extinguishing systems together with the operating instructions for the individual system components.
- The determination of size and the installation of the extinguishing system may only be carried out by trained personnel in accordance with all installation instructions and technical data sheets relating to this system.
- Responsibility for the correct implementation of the instructions in terms of the design and installation lies with the installer of the extinguishing system.

Aerosol extinguishing generators in the Dynaameco-PA01 series are designed for use in combination with the FiWaGuard-Sensor-hose-HR made by „FiWaRec Valves & Regulators GmbH & Co KG“.



Important:

We cannot be held responsible for the use of sensor hoses and pneumatic system components made by other manufacturers.

In all cases it must be ensured that prior to system installation the following operating requirements have been met:

1. Dimensions of the sensor hose connected to the extinguishing generators:
 - External diameter = 6 mm
 - Internal diameter = 4 mm
2. Operating pressure of hose system:
 - Nominal: 15 bar
 - Maximum: 20 bar
3. Operating pressure of pressure supply unit
 - Minimal: 150 bar



Caution:

- Under no circumstances should hoses be used that are not designed for use in a fire detection system.
- The use of system components which are not approved can lead to operating failure, false activations and accidents.

Operating Instructions

for aerosol extinguishing generators of the 200/300/2000 PA series

4. Storage

Dyameco aerosol extinguishing generators must be stored in the delivery packaging. They must be stored in a cool and dry place.

The extinguishing generator storage temperature must under no circumstances exceed or fall below the manufacturer's guaranteed operating range of -40°C to $+85^{\circ}\text{C}$.

5. Commissioning

Caution:

- The fire extinguishing system must be pressure-free in all assembly and installation work.
- The securing elements **6** for the aerosol extinguishing generators may only be removed once all assembly and installation work is complete.
- The temperature at the place of installation must not exceed the continuous operating temperature of the pneumatic system components used. The guaranteed operating temperature range of the Dyameco-PA01 extinguishing generators, which is -40°C to $+85^{\circ}\text{C}$, must be maintained in all cases.
- A minimum temperature of 10°C is required during assembly of the sensor hose system.
- During installation the operating instructions for the complete system and the operating instructions and technical data sheets for the other system components must be observed.

During installation the following points must be observed:

- a) The locations of aerosol extinguishing generators must be selected such that people and heat-sensitive objects are not directly exposed to the aerosol stream. A **min. distance of 1.5 m** must be maintained.
- b) The aerosol extinguishing generators must be securely fixed in the brackets provided. The locking method depends on the construction of the bracket used.

Important:

When locating the bracket, the direction ration must be taken

- c) Once the aerosol extinguishing generator has been fixed into the bracket, it should be checked to ensure it sits firmly in the correct position.

Caution:

The sensor hose system may only be connected once the aerosol extinguishing generators have been installed.

- d) Before making any hose connection it must be ensured the hose end is suitable for fitting.

Important:

The hose end to be connected must be cut such that it is smooth, at right angles and not squashed. It must also be free of burrs and dirt. In the event of any damage it must be cut again using a suitable tool.

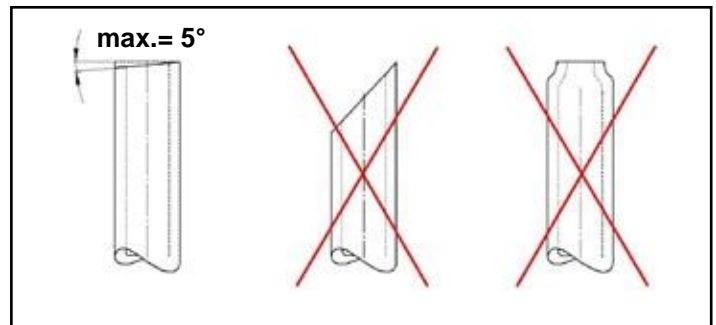

Fig 3: Cutting the sensor hose correctly

- e) To fix the sensor hose it should be pushed manually into the hose connector on the pneumatic tripping head and pressed in until noticeable resistance is felt. Once fitted the hose connection should be checked to make sure it fits tightly by pulling gently.

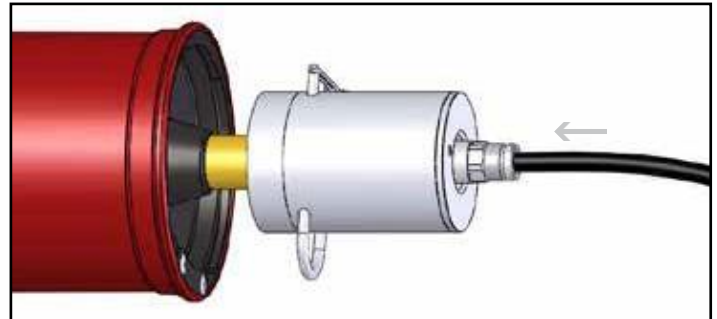

Fig 4: Connecting the sensor hose

Important:

No tool is necessary to make the hose connection. The use of tools in this part of the installation can damage the hose or connection adaptor.

Important:

When fitting the sensor hose care should be taken to ensure that it sits tightly against the limit stop (fig 5).

Operating Instructions

for aerosol extinguishing generators of the 200/300/2000 PA series



Dynamit Nobel Defence

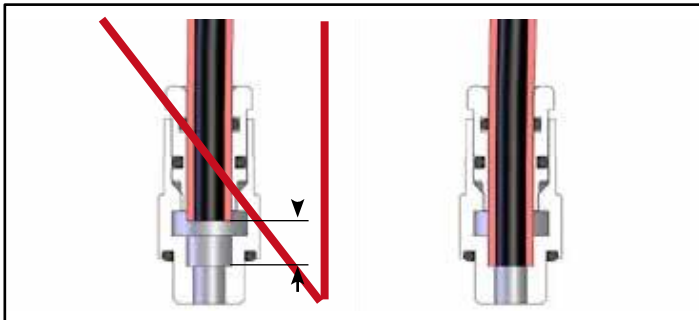

Fig 5: Fitting location of sensor hose

- f) It is possible to order aerosol fire extinguishing generators in the Dynameco-PA01 series already fitted in the factory with a sensor for activation signalling. On extinguishing generators of this optional design the activation sensor connection cable must be connected with the fire detection electronics used. For further information on connection please see the technical data sheets for the activation sensor.
- g) All hose connections fitted inside the extinguishing system must be checked after installation is complete to ensure a tight fit.
- h) After each aerosol extinguishing generator has been installed the fitting date must be recorded on the generator housing using the installation tags provided (Fig 6).



Fig 6: Assembly of the inspection sticker

6. Commissioning

Important:
When commissioning the complete extinguishing system the operating and installation instructions for pneumatic Dynameco fire extinguishing systems must also be observed.

The commissioning of a pneumatic fire extinguishing system using aerosol fire extinguishing generators from the Dynameco-PA01 series generally takes place with connection of the pressure supply unit. Before this step is taken it must be ensured that the subsequent inspection of all hose connections described in the section „Fitting and installation“ has been carried out.

Once this has been checked, pressure can be applied to the sensor hose system by operating the stop valve located in the pressure.

Important:
Once the system is pressurized it is vital that it is inspected for leaks. The procedure can be found in the operating instructions for pneumatic Dynameco fire extinguishing system.

Important:
After completing all installation work and checking the extinguishing system for leaks, the securing elements 6 of all extinguishing generators in the fire extinguishing system are to be removed (fig 7).
Aerosol extinguishing generators with securing elements still in place will not work!

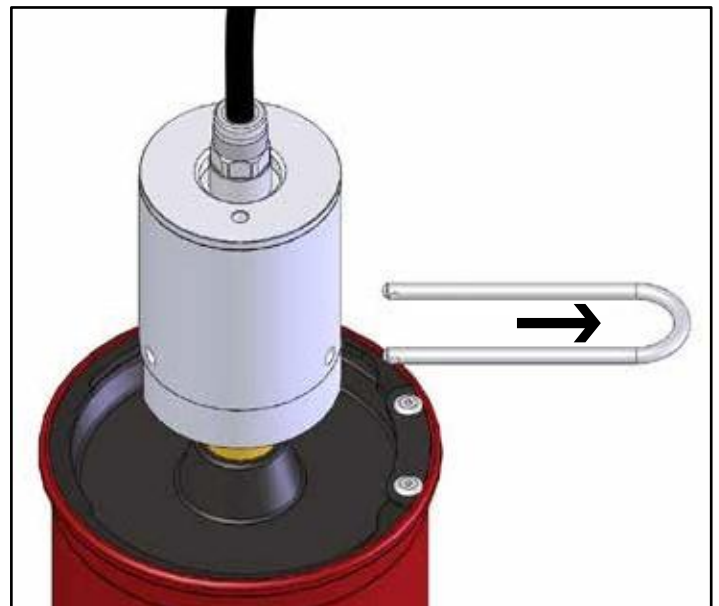

7. Disassembly

Caution:

- If the operational extinguishing generators need to be disassembled each individual generator must be provided with a securing element.
- The extinguishing generators to remain in the extinguishing system must also be secured.
- Whether the pressure is released intentionally or unintentionally in an extinguishing system with unsecured extinguishing generators this will inevitably lead to a false activation of all unsecured.

Operating Instructions

for aerosol extinguishing generators of the 200/300/2000 PA series



Caution:

- **After the extinguishing process the housing of the aerosol extinguishing generators is very hot – beware risk of burns!**
- **Should disassembly be necessary immediately after the extinguishing process then the appropriate tools and protective means should be used.**

After securing all extinguishing generators in the system, disassembly is carried out as follows:

- a) The system pressure accumulator is separated from the rest of the system by operating the shut-off valve.
- b) After shutting off the power supply, pressure should be released from the hose system. The procedure depends on the design of the extinguishing system.



Important:

The system is ventilated either by operating a special ventilation adaptor or a manual activation device (fig 9) depending on the design. In either case, the operating instructions for the extinguishing system must be observed.

- c) The pressure accumulator unit is then separated from the extinguishing system by releasing the appropriate hose connection.
- d) The hose connections of the individual extinguishing generators can now be released without danger.

The sensor hose is released by lightly pressing the hose connection collet whilst pulling the hose in the opposite direction (fig 8).

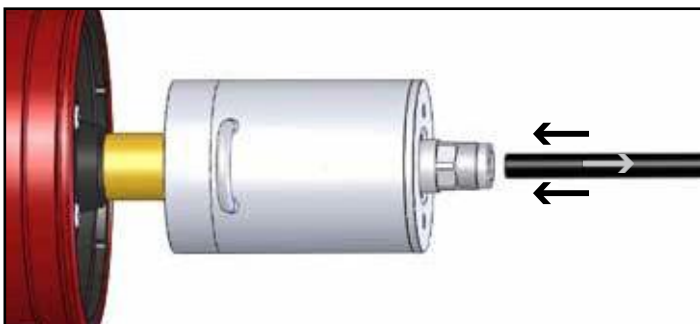

Fig 8: Disassembly of sensor hose



Important:

When removing the sensor hose care should be taken to ensure that both the hose and the hose connection remain undamaged. To make this procedure easier it is possible to obtain a removal tool 5 to hold down the collet.

- e) After releasing the hose connection the bracket for the corresponding extinguishing generator can be released and the extinguishing generator removed.

8. Periodic monitoring of aerosol extinguishing generators in the Dynameco-PA series

Aerosol extinguishing generators in the Dynameco-PA01 series are to be inspected regularly depending on the environmental conditions at their location to ensure they are externally intact and serviceable.

The inspection frequency must consider local regulations, the installation conditions and any resulting stress conditions. If the aerosol extinguishing generators to be monitored are exposed to specific stresses such as large temperature fluctuations or contamination, then a weekly inspection is recommended.

Generally, each extinguishing generator should be checked within the framework of an annual inspection together with the complete pneumatic extinguishing system.



Important:

Whenever there is an intervention on the extinguishing system during inspection, all extinguishing generators used should be provided with a securing element.

Special attention must be paid to the following points when inspecting a Dynameco-PA01 series aerosol extinguishing generator:

- a) The aerosol extinguishing generator must sit firmly in the bracket provided.
- b) The installation date should be checked on the installation tag (fig 6).
- c) The housing of the aerosol extinguishing generator should not be dented or damaged. If it is then the extinguishing generator must be replaced.
- d) The foil which seals the extinguishing generator on the extinguishing agent discharge side should not be damaged or excessively contaminated with varnish or similar substances which could prevent correct opening in the event of a fire. If it is, then the aerosol extinguishing generator must be replaced or the contamination removed from the foil.
- e) The connected hose must be correctly secured in the hose connector



Important:

The foil must not be damaged during cleaning.

Operating Instructions

for aerosol extinguishing generators of the 200/300/2000 PA series

9. Disposal

Once activated, Dynameco aerosol extinguishing generators can be disposed of with the household waste.



Caution:

Under no circumstances should aerosol extinguishing generators be disposed of with household waste without previous activation.

Extinguishing generators in working order which need to be disposed of due to age or damage please contact the manufacturer or sales partner.

In individual cases it may be appropriate for customers to dispose of extinguishing generators. If so a controlled activation must be induced observing the following points:

- Only undamaged extinguishing generators may be disposed of by the customer.
- All requirements described in these instructions for safe installation and handling must be observed.
- The extinguishing generators must be adequately secured when activated.
- The aerosol cloud produced upon activation must not have any detrimental effect on the environment.
- For safe activation a pneumatic manual activation device (fig 9) should be used.



Fig 9: Manual activation device for pneumatic extinguishing systems



Caution:

For damaged aerosol extinguishing generators please contact the sales partner or the manufacturer. They should not be disposed of by the customer.

10. Age restrictions



Important:

Dynameco aerosol fire extinguishing generators may only be operated by trained persons who are at least 18 years old. (Different regulations may apply in countries outside the European Union).

11. Warnings to prevent misuse



Important:

- Aerosol extinguishing generators may only be stored in packaging authorized for this purpose.
- They may only be removed for installation.
- The requirements for storage and use described in these instructions must be observed.
- Only externally intact aerosol extinguishing generators should be installed. Damaged extinguishing generators please contact the sales partner or the manufacturer.
- Aerosol extinguishing generators should under no circumstances be opened. Attempts to open them mechanically, the introduction of objects from outside and the application of untypical mechanical stresses are not permitted.
- Aerosol extinguishing generators must be kept away from permanent heat sources of any type (open fire, fan heaters, radiators etc.). The storage and operating temperatures described above must be observed.
- Instructions on the safety data sheet, the technical data sheets and the cleaning instructions.

Operating Instructions

for aerosol extinguishing generators of the 200/300/2000 PA series

12. Assembly drawing Dynameco PA01

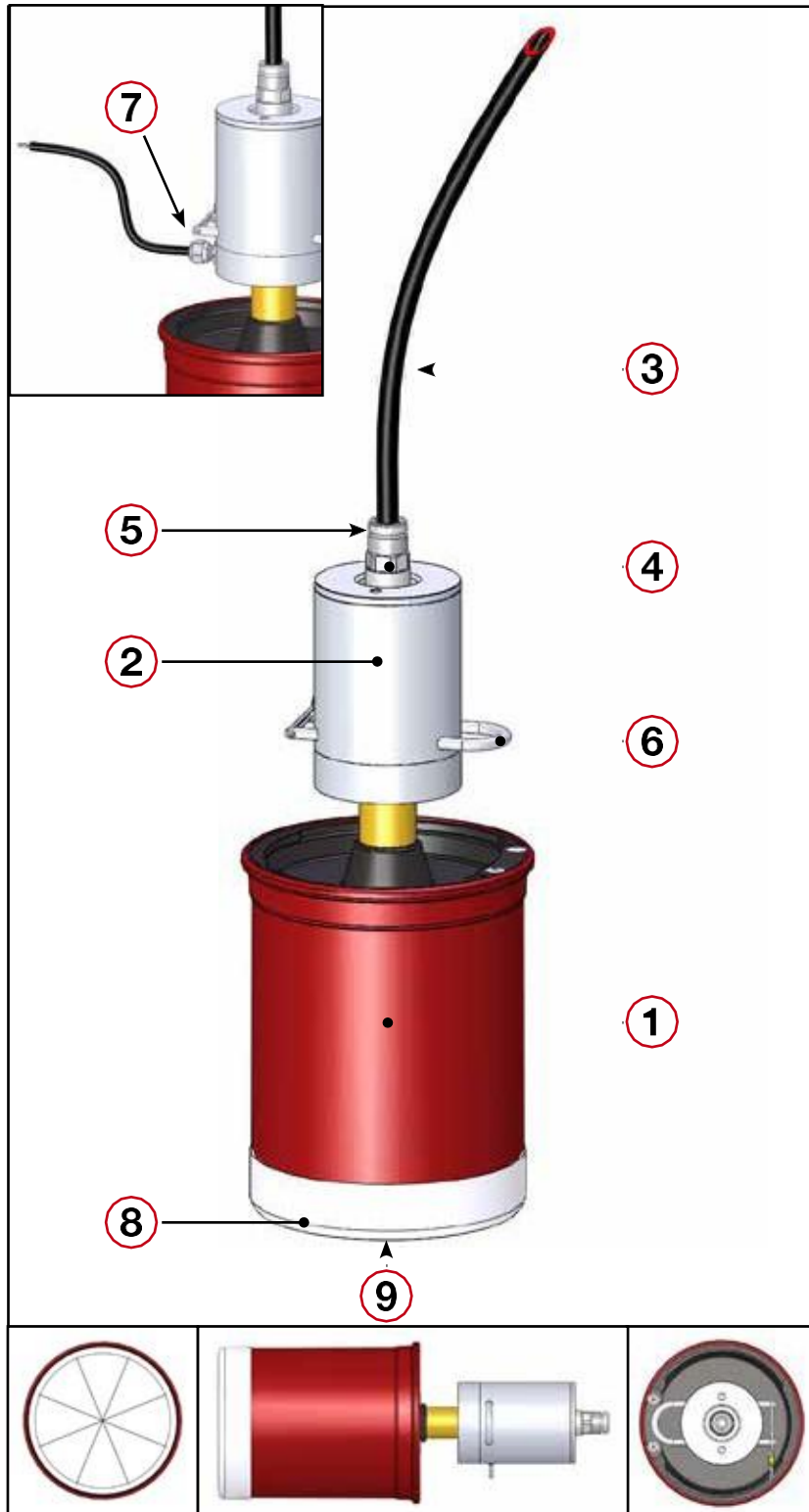

- ① Generator
- ② Tripping head
- ③ Head sensor
- ④ Hose
- ⑤ Collet
- ⑥ Securing element
- ⑦ Activation sensor (optional)
- ⑧ Foil seal
- ⑨ Discharge side extinguishing agent